



V250CE

EN

Short Stroke Block Cylinder with
Magnetic Switches, Light Series

DE

Hydraulische Kurzhubzylinder mit
magnetischen Endschaltern, leichte Reihe

IT

Cilindri oleodinamici a corsa breve con
sensori magnetici di fine corsa, serie leggera

FR

Vérins hydrauliques courses courtes avec
détecteurs magnétiques de fin de course,
série légère

250
BAR



VEGA[®]
CYLINDERS

ALBA
ENTERPRISES

CONTACT FOR NORTH AMERICAN
SALES AND TECHNICAL SUPPORT:

PH: 909.941.0600 • Email: info@albaent.com
www.ALBAENT.com

EN

ORDER CODE

DE

BESTELLCODE

IT

CODICE ORDINE

FR

CODE COMMANDE

V250 CE

Cylinder Model
Zylinder Modell
Modello cilindro
Modèle du vérin

CE

Bore

Bohrung
Alésaggio
Alésage

025

Clamping Style

Befestigungs Art
Fissaggio
Fixation

E

Oil Ports Type

Art der Anschlüsse
Tipo di orifici
Type d'orifice

G

Oil Ports Position

Lage der Leitungsanschlüssen
Posizione orifici
Position des orifices

H

PAGE SEITE PAGINA PAGE

E6

E8 > E10

E8 > E10

E8 > E10

ØX

025

032

040

050

063

080

100

C

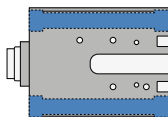

E

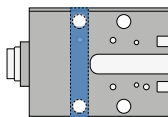

G

Standard BSP (Gas) Thread
BSP (Gas) Gewinde
Filetto standard BSP (gas)
Filetage BSP (gas)

N

NPT Thread
NPT Gewinde
Filetto NPT
Filetage NPT

O

Manifold with O-Rings
Ölanschluß durch O-Ringe
Integrati con O-ring
Intégrés avec joint torique

H

Left Side (Threaded)
Gewinde links
Sinistra (filettati)
Gauche (fileté)

M

Right Side (Threaded)
Gewinde rechts
Destra (filettati)
Droite (fileté)

F

Front Side (O-Rings)
Frontale Ölanschlüsse (durch O-Ringe)
Frontale (O-ring)
Avant (O-rings)

E

Bottom Side (O-Rings)
Seitliche Ölanschlüsse (durch O-Ringe)
Lato inferiore (O-ring)
Dessous (O-rings)

R

Rear Side (O-Rings)
Hintere Ölanschlüsse (durch O-Ringe)
Posteriori inferiore (O-ring)
Arrière (O-rings)

D

Left+Right Side (Threaded)
Rechts und Links Ölanschlüsse (mit Gewinde)
Sinistro+destro (filettato)
Gauche + droite (fileté)

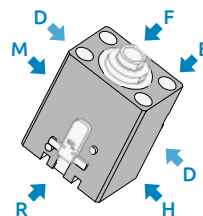
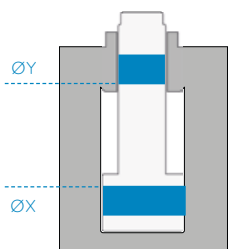

Rod end Type
Kolbenstangen Ausführung
Estremità stelo
Extrémité de la tige

Cylinder Version
Zylinder-Version
Versione cilindro
Version vérin

Stroke
Hublänge
Corsa
Course

Rod Accessories
Zubehör Kolbenstange
Accessori stelo
Accessoires de la tige

Magnetic Switches
Magnetische Endschalter
Sensori magnetici
DéTECTEURS magnétiques

G

M

020

+

MTA10X150

\

MSU2

E11

E11

E7

E15

E13

G

Female Metric Thread
Metrisches Innengewinde
Filetto femmina metrico
Taroudage métrique

I

Female UNF Thread
UNF Innengewinde
Filetto femmina UNF
Taroudage UNF-UNEF

M

Cylinder with Magnetic Preset
Zylinder mit Magnet
Cilindro con predisposizione magnetica
Vérin avec predisposition magnétique

N

Cylinder without Magnetic Preset
Zylinder ohne Magnet
Cilindro senza predisposizione magnetica
Vérin sans predisposition magnétique

Z

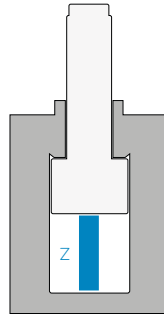

#



None
Keiner
Nessuno
Aucun

MTA

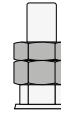

Male Thread
Aussengewinde
Filetto maschio
Filetage

MFA

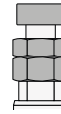

Floating Joint
Hammerkopf
Testa a martello
Tenon

DFA



Floating Joint with Female
Hammerkopf mit Gegenstück
Testa a martello con femmina
Tenon male/femelle

#

None
Keiner
Nessuno
Aucun

MSU2

Magnetic Switches
Magnetische Endschalter
Sensori magnetici
DéTECTEURS magnétiques

MSU3

Magnetic Switches
Magnetische Endschalter
Sensori magnetici
DéTECTEURS magnétiques

V250 CE

EN

TECHNICAL AND WORKING CHARACTERISTICS CHART

DE

TABELLE TECHNISCHE MERKMALE UND FUNKTION

IT

TABELLA CARATTERISTICHE TECNICHE E DI FUNZIONAMENTO

FR

TABLEAU DES CARACTÉRISTIQUES TECHNIQUES ET DE FONCTIONNEMENT

V250CE

	Maximum Working Pressure	Maximale Druck	Pressione massima di esercizio	Pression maximale d'exercice
ØX	Manifold oil delivery* Ölanschluß durch O-Ringe* Alimentaz. con O-ring* Alimentation avec O-ring*		Threaded oil delivery Gewindebohrungen Orifici filettati Orifices filetés	
	MPa - (bar) - PSI		MPa - (bar) - PSI	
25	16(160) - 2320		25(250) - 3625	
32	16(160) - 2320		25(250) - 3625	
40	14(140) - 2030		25(250) - 3625	
50	14(140) - 2030		25(250) - 3625	
63	12(120) - 1740		20(200) - 2900	
80	12(120) - 1740		18(180) - 2610	
100	12(120) - 1740		18(180) - 2610	

* : Oil delivery with manifold at higher pressures can cause oil leakage from oil delivery O-rings.

* : Übersteigt der Betriebsdruck die angegebenen Werte, führt dies bei Zylindern mit Anschluss über O-Ringe zum Ölaustritt an den O-Ringen.

* : L'uso dei cilindri con alimentazione integrata a pressioni superiori può provocare perdite di olio dagli O-ring di alimentazione.

* : L'utilisation du vérin avec alimentation intégrée à une pression supérieure peut provoquer une fuite d'huile au niveau des O-rings d'alimentation.

ØX = Bore Bohrung Alesaggio Alésage

<p>Maximum Nominal Delivery (Pushing) Nennwert Max. Durchflussmenge (beim Ausfahren) Portata max. nominale Débit nominal maximum (en poussée)</p>	<p>Maximum Piston Speed Maximale Geschwindigkeit des Kolbens Velocità massima pistone Vitesse maximum du vérin</p>	<p>Maximum Working Temperature Max. Betriebstemperatur Temperatura max. esercizio Température max. d'exercice</p>
---	---	--

ØX		<p>Magnetic Cylinder Magnetische Zylinder Cilindro magnetico Vérin magnétique</p>	<p>Non-Magnetic Cylinder Nicht magnetische Zylinder Cilindro non magnetico Vérin normal</p>
----	--	--	--

	l/min	m/s		
25	1			
32	2			
40	3			
50	5	0,05	80°C 176° F	100°C 212°F
63	10			
80	15			
100	20			

EN

BORE SIZE AND STROKE

DE

KOLBENDURCHMESSER UND HUBLÄNGE

IT

ALESAGGIO E CORSA

FR

ALÉSAGES ET COURSES

CE

ØX

025

E

G

H

Table for push and pull forces in daN (1 daN = 1 kgf)

Tabelle druck- und zugkraft in daN (1 daN=1 kgf)

Tabella forze in spinta e tiro in daN (1 daN = 1 kgf)

Tableau des forces de poussée et de traction en daN (1 daN=1 kgf)

V250 CE

ØX	ØY	8 MPa 80 bar 1160 PSI		10 MPa 100 bar 1450 PSI		12,5 MPa 125 bar 1812 PSI		16 MPa 160 bar 2320 PSI		20 MPa 200 bar 2900 PSI	
		Th	Tr	Th	Tr	Th	Tr	Th	Tr	Th	Tr
025	18	393	189	491	236	613	295	785	378	981	473
032	22	643	339	804	424	1005	530	1286	678	1608	848
040	22	1005	701	1256	876	1570	1095	2010	1402	2512	1752
050	28	1570	1078	1963	1347	2453	1684	3140	2155	3925	2694
063	28	2493	2000	3116	2500	3895	3125	4985	4000	6231	5000
080	36	4019	3205	5024	4007	6280	5008	8038	6411	-	-
100	45	6280	5008	7850	6260	9813	7825	12560	10017	-	-

Th Thrust Druck Spinta Poussée

Tr Traction Zug Trazione Traction

ØX Bore Bohrung Alesaggio Alésage

ØY Rod Kolbenstange Stelo Tige

G M **Z** 020 + MTA10X150 \ MSU2

Standard strokes table in mm

Standard hublängen tabelle in mm

Tabella corse standard in mm

Tableau des course standards en mm

Z	020	050	080
ØX			
25			
32			
40			
50			
63			
80			
100			

ØX Bore Bohrung Alesaggio Alésage
 Z Stroke Hub Corsa Course

V250CE

Standard strokes Standard Hublängen Corse standard Courses standard

NOTES: Stroke tolerance: -0/+0.5 mm. For intermediate strokes, choose the closest longer stroke, and require a stroke reducer (minimum reduction: 8 mm). Special strokes can be requested to our Sales Department.

BEMERKUNG: Toleranz Hublänge: -0/+0,5 mm Für Zwischenhublängen nächsthöheres Standardmaß wählen und Hubbegrenzung anfordern (Mindestreduzierung: 8mm). Sonderhublängen sind auf Anfrage lieferbar. Wenden Sie sich an unseren Verkauf.

NOTE: Tolleranza sulla corsa: -0/+0,5 mm. Per corse intermedie considerare la corsa immediatamente superiore e richiedere il riduttore di corsa (riduzione minima: 8 mm). Si possono richiedere corse speciali contattando il nostro ufficio vendite.

NOTE: Tolérance sur la course -0/+0,5 mm Pour les courses intermédiaires considérer la course immédiatement supérieure et demander le réducteur de course (au minimum 8 mm). Courses spéciales sur demande. Contacter notre service commercial.

Tightening torque for cylinder-mold fixing screws

Anzugsmomente zur Verriegelung von Zylinder an der Form

Coppie di serraggio per viti di fissaggio cilindro-stampo

Couple de serrage pour les vis de fixation du vérin sur le moule

ØX	Nm
25	24,6
32	45
40	45
50	80
63	80
80	150
100	150

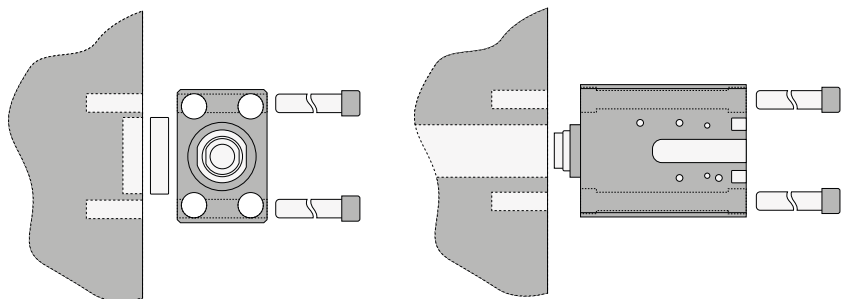

ØX = Bore Bohrung Alesaggio Alésage

ØX

CE

025

E

G

H

E G H

Key-way clamping with BSP (Gas) threaded oil delivery, left side

Nutbefestigung und Gewindeanschluss BSP (Gas), links

Fissaggio a piedino con orifizi filettati BSP (gas), lato sinistro

Fixation par trous verticaux avec orifices filetés BSP (gas), côté gauche

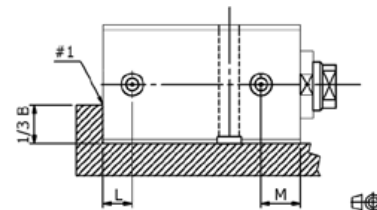
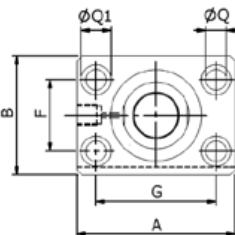
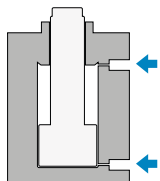

E N H

Key-way clamping with NPT threaded oil delivery, left side

Nutbefestigung und Gewindeanschluss NPT, links

Fissaggio a piedino con orifizi filettati NPT, lato sinistro

Fixation par trous verticaux avec orifices filetés NPT, côté gauche

#1: If this clamping style is adopted and oil pressure in the cylinder is higher than 160 bar = 2320 PSI, we advise to use a holding "wall" to avoid any deflection.

Wenn der Zylinder mit dieser Befestigungsart über 160 bar = 2320 PSI betrieben wird, sollte eine Vorrichtung wie nach Zeichnung verwendet werden, um jede Durchbiegung zu vermeiden.

Se con questo fissaggio si usa il cilindro a pressioni oltre 160 bar = 2320 PSI, consigliamo l'uso di un sostegno come da disegno, per evitare ogni flessione.

Si avec cette fixation on utilise le vérin à pressions supérieures à 160 bars = 2320 PSI, on conseille l'utilisation d'un soutien comme dans le dessin, pour éviter toute flexion.

E G M

Key-way clamping with BSP (Gas) threaded oil delivery, right side

Nutbefestigung und Gewindeanschluss BSP (Gas), rechts

Fissaggio a piedino con orifizi filettati BSP (gas), lato destro

Fixation par trous verticaux avec orifices filetés BSP (gas), côté droit

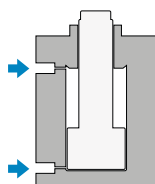

Key-way clamping with NPT threaded oil delivery, right side

Nutbefestigung und Gewindeanschluss NPT, rechts

Fissaggio a piedino con orifizi filettati NPT, lato destro

Fixation par trous verticaux avec orifices filetés NPT, côté droit

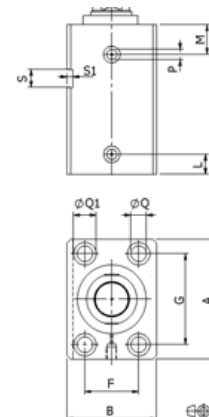
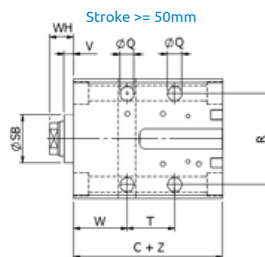
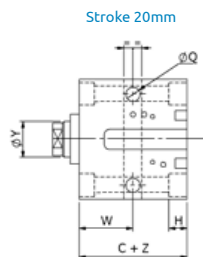

E N M

All cylinders with BSP right side oil delivery and NPT left or right side oil delivery can have a tip on the side opposite the oil delivery. See measuring "T2" and ØT1 (see page E9).

Zylinder mit Anschluss BSP rechts oder NPT rechts und links könnten auf der gegenüberliegenden Seite der anschlüsse verschlussverschraubungen haben. Siehe hierzu Maße "T2" und ØT1 (E9).

I cilindri con alimentazione BSP destra o NPT destra e sinistra potrebbero avere un tappo sul lato opposto all'alimentazione. Vedere le quote "T2" e ØT1 (vedi pagina E9).

Les vérins avec alimentation en huile BSP côté droit et NPT côté gauche ou droit peuvent avoir un bouchon sur le côté opposé à l'alimentation. Voir la cote "T2" et ØT1 (voir page E9).

ØX	ØY	Z	T	C+	A	B	F	G	H	L	M	P NPT BSP	ØQ	ØQ1	R	S H10	S1	ØSB f8	V	W	WH	
25	18	20	-	57	65	45	30	50	9	12	22	1/4"	1/4"	8,5	13,5	50	10	2	32	6,5	37	14
		50	40																			
		80	70																			
32	22	20	-	60	75	55	35	55	11	12	22	1/4"	1/4"	10,5	16,5	55	12	3	34	8	40	15
		50	40																			
		80	70																			
40	22	20	-	73	85	63	40	63	11	14	24	1/4"	1/4"	10,5	16,5	63	12	3	34	7	43	17
		50	45																			
		80	75																			
50	28	20	-	75	100	75	45	76	13	14,5	25	1/4"	1/4"	13	19	76	15	5	42	8	45	20
		50	45																			
		80	75																			
63	28	20	-	85	115	90	55	90	13	21	29	3/8"	3/8"	13	19	90	15	5	50	7	55	20
		50	40																			
		80	70																			
80	36	20	-	100	140	110	75	110	17	25	35	1/2"	1/2"	17	25	110	20	5	60	7	60	20
		50	40																			
		-	-																			
100	45	20	-	110	170	140	95	135	17	28	37	1/2"	1/2"	17	25	135	20	5	72	8	70	25
		50	30																			
		-	-																			

NOTES: For dimensions where no tolerance is indicated, refer to DIN norm 7168-m. ACHTUNG: Für Maße ohne Tolleranzangaben gilt DIN 7168-m.

NOTE: Per le dimensioni senza indicazione di tolleranza, riferirsi alla norma DIN 7168-m.

NOTE: Pour les dimensions où la tolerance n'est pas indiquée, adressez-vous aux normes DIN 7168-m.

ØX

Bore

Bohrung

Alesaggio

Alésage

ØY

Rod

Kolbenstange

Stelo

Tige

Z

Stroke

Hub

Corsa

Course

eg. ØX = 25, ØY = 18, Z = 20mm : C + Z = 57 + 20 = 77 mm

G M Z 020 + MTA10X150 \ MSU2

EGD

Key-way clamping with BSP (Gas) threaded double oil delivery, left + right side

Nutbefestigung und beidseitiger Gewindeanschluss BSP (Gas), rechts + links

Fissaggio a piedino con doppi orifizi filettati BSP (gas), lato sinistro + destro

Fixation par trous verticaux avec doubles orifices filetés BSP (gas), côté droit + côté gauche

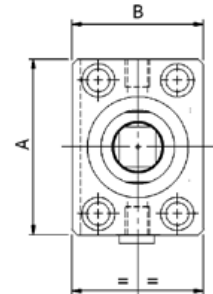
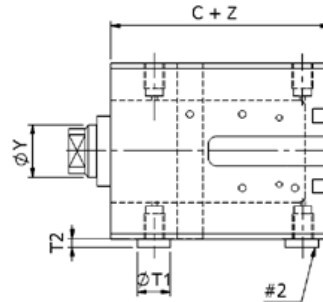
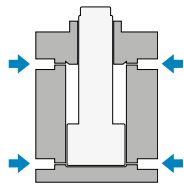

V250CE

Key-way clamping with NPT threaded double oil delivery, left + right side

Nutbefestigung und beidseitiger Gewindeanschluss NPT, rechts + links

Fissaggio a piedino con doppi orifizi filettati NPT, lato sinistro + destro

Fixation par trous verticaux avec doubles orifices filetés NPT, côté droit + côté gauche

END

EOE

Key-way clamping with bottom manifold oil delivery

Nutbefestigung und integrierte Anschlüsse über O-Ringe, seitlich

Fissaggio a piedino con orifizi integrati inferiori

Fixation par trous verticaux avec orifices intégrés dessous

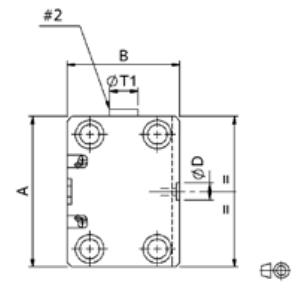
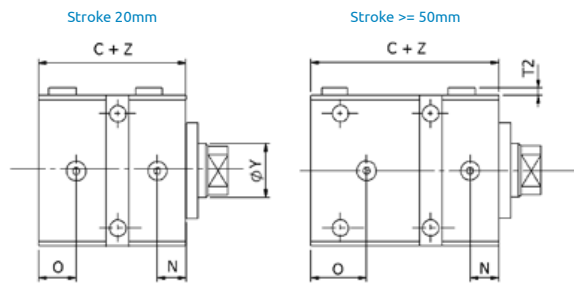
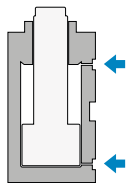

#2: Warning: Caps (T2) protrude on the left or on the right side. Max. eccentricity mm 0,5 - O-rings included in the supply.

Achtung: Auskragung der Verschlüsse (T2) auf rechter oder linker Seite. Unmittigkeit max 0,5 mm - O-Ringe im Lieferumfang enthalten.

Attenzione: Sporgenza tappi (T2) sul lato sinistro o sul destro. Eccentricità max 0,5 mm - O-ring compresi nella fornitura.

Attention: Bouchons dépassant (T2) sur le côté gauche ou sur le côté droit. Excentricité max 0,5 mm - O-rings inclus dans la fourniture.

ØX	ØY	C +	A	B	ØD	N	O	ØT1	T2
25	18	57	65	45	10	22	7	19	5
32	22	60	75	55	10	22	7	19	5
40	22	73	85	63	10	24	10	19	5
50	28	75	100	75	10	25	10	19	5
63	28	85	115	90	13	29	15	22	5
80	36	100	140	110	13	35	17	27	5
100	45	110	170	140	13	37	20	27	5

NOTES: For dimensions where no tolerance is indicated, refer to DIN norm 7168-m.

ACHTUNG: Für Maße ohne Tolleranzangaben gilt DIN 7168-m.

NOTE: Per le dimensioni senza indicazione di tolleranza, riferirsi alla norma DIN 7168-m.

eg. ØX = 25, ØY = 18, Z = 20mm : C + Z = 57 + 20 = 77 mm

NOTE: Pour les dimensions où la tolerance n'est pas indiquée, adressez-vous aux normes DIN 7168-m.

ØX Bore Bohrung Alesaggio Alésage ØY Rod Kolbenstange Stelo Tige Z Stroke Hub Corsa Course

ØX

CE

025

C

O

F

COF

Longitudinal through holes with front manifold oil delivery

Durchgangsbohrungen und integrierte Anschlüsse über O-Ringe, vorne

Fissaggio fori longitudinali passanti con orifizi integrati frontali

Trous passants longitudinaux avec orifices intégrés avant

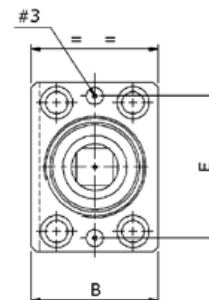
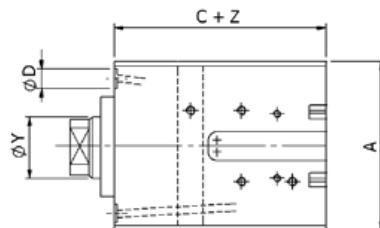
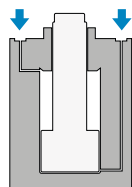

V250 CE

COR

Longitudinal through holes with rear manifold oil delivery

Durchgangsbohrungen und integrierte Anschlüsse über O-Ringe, hinten

Fissaggio fori longitudinali passanti con orifizi integrati posteriori

Trous passants longitudinaux avec orifices intégrés arrière

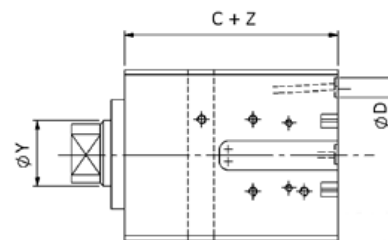
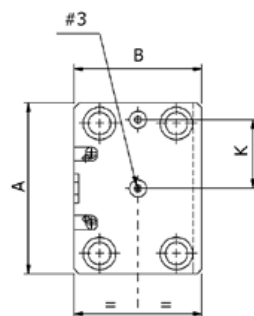
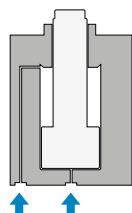

#3: Max. diameter of oil delivery hole in the plate: 3 mm (Cylinders Ø25÷50) and 5 mm (Cylinders Ø63÷100). Max. eccentricity mm 0,5 - O-rings included in the supply.

Max. Durchmesser der Ölversorgungsbohrungen in der Platte: Max 3mm (Ø 25-50) und Max 5mm (Ø 63-100). Unmittigkeit: Max. 0,5mm; O-Ringe werden mitgeliefert.

Diametro max del foro di alimentazione sulla piastra: 3 mm (cilindri Ø25÷50) e 5 mm (cilindri Ø63÷100). Eccentricità max 0,5 mm - O-Ring compresi nella fornitura.

Diamètre maxi du trou d'alimentation sur la plaque: 3 mm (vérins Ø25÷50) et 5 mm (vérins Ø63÷100). Excentricité maxi 0,5 mm. Les joints toriques font partis de la livraison.

ØX	ØY	C +	A	B	ØD	E	K
25	18	57	65	45	10	51	25,5
32	22	60	75	55	10	60	30
40	22	73	85	63	10	65	32,5
50	28	75	100	75	10	80	40
63	28	85	115	90	13	95	47,5
80	36	100	140	110	13	118	59
100	45	110	170	140	13	140	70

NOTES: For dimensions where no tolerance is indicated, refer to DIN norm 7168-m.

ACHTUNG: Für Maße ohne Tolleranzangaben gilt DIN 7168-m.

NOTE: Per le dimensioni senza indicazione di tolleranza, riferirsi alla norma DIN 7168-m.

NOTE: Pour les dimensions où la tolerance n'est pas indiquée, adressez-vous aux normes DIN 7168-m.

eg. ØX = 25, ØY = 18, Z = 20mm : C + Z = 57 + 20 = 77 mm

ØX

Bore Bohrung Alesaggio Alésage

ØY

Rod Kolbenstange Stelo Tige

Z

Stroke Hub Corsa Course

EN

CHOICE OF ROD END STYLE

IT

SCELTA DELL' ESTREMITÀ DELLO STELO

DE

AUSWAHL KOLBENSTANGENENDE

FR

CHOIX DE L'EXTREMITÉ DE LA TIGE

G

M

Z

020

+ MTA10X150

\ MSU2

Description of Rod end Style

Beschreibung des Kolbenstangenendes

Descrizione tipo di estremità

Description du type d'extrémité de la tige

G

Metric Female Thread - Standard

Metrisches Innengewinde - Standard

Filetto femmina metrico - Standard

Taraudage métrique - Standard

I

UNF-UNEF Female Thread (U.S.A. Standard)

UNF-UNEF Innengewinde (U.S.A. Standard)

Filetto femmina UNF-UNEF (Standard U.S.A.)

Taraudage UNF-UNEF (Standard U.S.A.)

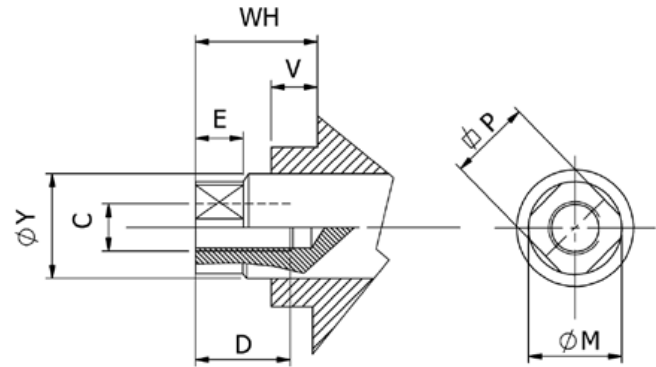

V250CE

ØX	ØY	C		D	E	ØM ϕ	P	V	WH
		METRIC	UNF						
25	18	M10×1,5	3/8-24	20	6	17	15	6,5	14
32	22	M12×1,75	1/2-20	20	5,5	21	18	8	15
40	22	M14×2	9/16-18	20	5,5	21	18	7	17
50	28	M20×2,5	3/4-16	30	8	27	24	8	20
63	28	M20×2,5	3/4-16	30	8	27	24	7	20
80	36	M27×3	1-12	40	11	35	32	7	20
100	45	M33×3,5	1-1/4-12	50	12	44	40	8	25

NOTES: For dimensions where no tolerance is indicated, refer to DIN norm 7168-m.

ACHTUNG: Für Maße ohne Tolleranzangaben gilt DIN 7168-m.

NOTE: Per le dimensioni senza indicazione di tolleranza, riferirsi alla norma DIN 7168-m.

NOTE: Pour les dimensions où la tolerance n'est pas indiquée, adressez-vous aux normes DIN 7168-m.

ØX

Bore Bohrung Alesaggio Alésage

ØY

Rod Kolbenstange Stelo Tige

Z

Stroke Hub Corsa Course

EN

CHOICE OF CYLINDER VERSION

DE

AUSWAHL DER ZYLINDERVERSION

IT

SCELTA DELLA VERSIONE DEL CILINDRO

FR

CHOIX DE LA VERSION DU VÉRIN

ØX

CE

025

E

G

H

V250 CE

	Description	Beschreibung	Descrizione	Description
M	<p>Magnetic switches preset</p> <p>Ausgerüstet für magnetische Abfrage</p> <p>Predisposto ai sensori magnetici</p> <p>Prédisposition pour détecteurs magnétiques</p>			
N	<p>Without magnetic switches preset</p> <p>Ohne Ausrüstung für magnetische Abfrage</p> <p>Non predisposto ai sensori magnetici</p> <p>Sans prédispositon pour détecteurs magnétiques</p>			

Switches to be ordered separately from the cylinder.

Magnetschalter separat bestellen.

Sensori da ordinare separatamente al cilindro.

Détecteurs a commander séparément du vérin.

G

M

Z

020

+ MTA10X150 \

MSU2

\

None Keiner Nessuno Aucun

# \ #	ØX	ØY	Z
MSU2			20
MSU2	25	18	50
MSU3			80
MSU2	32	22	20
MSU2			50
MSU3			80
MSU2	40	22	20
MSU3			50
MSU3			80
MSU2	50	28	20
MSU3			50
MSU3			80
MSU3	63	28	20
MSU3			50
MSU3			80
MSU3	80	36	20
MSU3			50
-			-
MSU3	100	45	20
MSU3			50
-			-

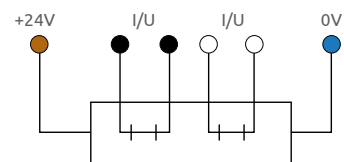
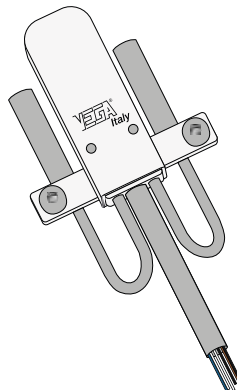
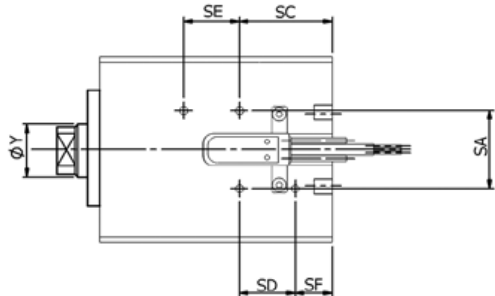

Wire Color Anschlussfarben Colore conduttori Couleurs des conducteurs

- Brown Braun Marrone Brun = +24V DC
- Blue Blau Blu Bleu = 0V DC
- Black Schwarz Nero Noir = In/Out Contact Kontakt Contatto Contact
(Back position Zurück Position Posizione indietro Position de retour)
- White Weiß Bianco Blanc = In/Out Contact Kontakt Contatto Contact
(Forward position Vordere position Posizione in avanti Position avant)

I/U = In/Out

ØX	ØY	Z	SC	SD	SE	SA	SF	I	J
25	18	20	27,5	-	-	28	20	3	8
		50	30	35	30				
		80	60	35	30				
32	22	20	35	-	-	30	20	3	8
		50	40	30	30				
		80	70	30	30				
40	22	20	50	-	-	36	20	3	8
		50	50	30	30				
		80	80	30	30				
50	28	20	50	-	-	42	20	3	8
		50	50	30	30				
		80	80	30	30				
63	28	20	60	-	-	56	30	3	8
		50	60	30	30				
		80	90	30	40				
80	36	20	70	-	-	65	33	3	8
		50	70	37	30				
		-	-	-	-				
100	45	20	77	-	-	56	47	3	8
		50	77	30	30				
		-	-	-	-				

ØX Bore Bohrung Alesaggio Alésage

ØY Rod Kolbenstange Stelo Tige

Z Stroke Hub Corsa Course

EN **ROD END ACCESSORIES**
for rod metric or UNF thread

IT **ACCESSORI STELO**
per estremità filetto stelo metrico o UNF

DE **ZUBEHÖR KOLBENSTANGE**
für innengewinde metrisch oder UNF

FR **ACCESSOIRES DE LA TIGE**
pour extrémité taraudée métrique ou UNF

CE ØX: 025 E G H

None Keiner Nessuno Aucun

V250CE

MTA 10X150

Metric Male Thread
Metrisches Aussengewinde
Filetto maschio metrico
Filetage male métrique

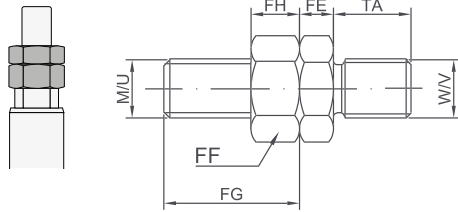

METRIC (G)	UNF-UNEF (I)	ØX	ØY	#1	
10X150	3/8-24	25	18	G	I
12X175	1/2-20	32	22	G	I
14X200	9/16-18	40	22	G	I
20X250	3/4-16	50	28	G	I
20X250	3/4-16	63	28	G	I
27X300	1-12	80	36	G	I
33X350	1-1/4-12	100	45	G	I

MFA

Floating Joint
Hammerkopf
Testa a martello
Tenon

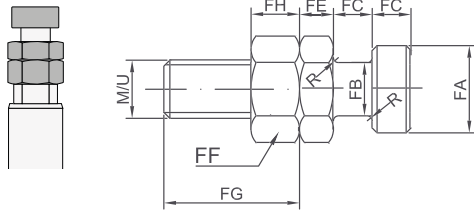

#1 : **Compatible rod end code**
Kode für passende Ausführung Kolbenstangenende
Cod. estremità stelo compatibile
Cod. extrémité tige compatible

DFA

Floating Joint With Female
Hammerkopf mit Gegenstück
Testa a martello con femmina
Tenon avec femelle

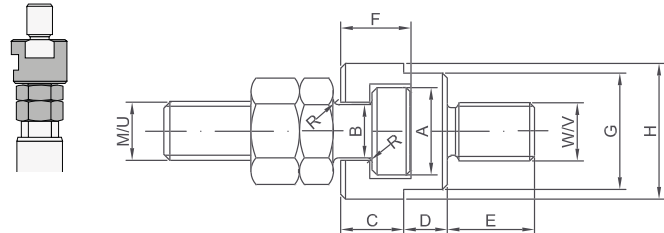

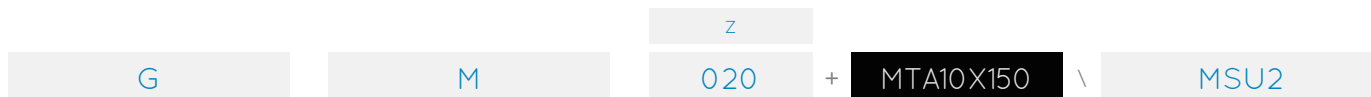

		METRIC		UNF-UNEF		A	B	C	D	E	F	G	H	FA	FB	FC	FE	FF	FG		FH		TA	R
		M	W	U	V														M	U	M	U		
10X150	3/8-24	M10×1,5	M10×1,25	3/8-24	3/8-24	17,5	11	11	8	16	12,5	21	25	16	10	7	6	17	24	24	8	6	14	1
12X175	1/2-20	M12×1,75	M12×1,25	1/2-20	1/2-20	19,5	12	13	9	18	14,5	24	28	18	11	8	7	19	28	28	10	8	16	1,2
14X200	9/16-18	M14×2	M14×1,5	9/16-18	9/16-18	19,5	12	13	9	22	14,5	24	28	18	11	8	8	22	33	33	11	9	18	1,2
20X250	3/4-16	M20×2,5	M20×1,5	3/4-16	3/4-16	24	15	16	10	28	17,5	30	36	22	14	10	9	30	44	39	16	11	28	1,2
27X300	1-12	M27×3	M27×2	1-12	1-12	30	19	20	12	40	23	36	44	28	18	12,5	12	36	57	52	22	14	36	1,5
33X350	1-1/4-12	M33×3,5	M33×2	1-1/4-12	1-5/16-18	39	23	26	14	50	27,5	46	55	35	22	16	14	46	64	64	14	27	45	2

V250 CE

NOTES: For dimensions where no tolerance is indicated, refer to DIN norm 7168-m.

ACHTUNG: Für Maße ohne Tolleranzangaben gilt DIN 7168-m.

NOTE: Per le dimensioni senza indicazione di tolleranza, riferirsi alla norma DIN 7168-m.

NOTE: Pour les dimensions où la tolerance n'est pas indiquée, adressez-vous aux normes DIN 7168-m.

ØX Bore Bohrung Alesaggio Alésage

ØY Rod Kolbenstange Stelo Tige

Z Stroke Hub Corsa Course

General & technical features

Technische merkmale

Caratteristiche generali

Caractéristiques techniques

Max. heat resistance (for short periods) Maximale Spitztemperatur (kurzfristig) 280 °C
 Temperatura max. di picco (per breve periodo) Température maxi de pointe (pour une période très brève)

Max. working temperature Maximaler Betriebstemperatur 240 °C
 Temperatura max. di esercizio Température maxi de travail

Thermal conductivity Thermische Leitfähigkeit 0,24 W/mk
 Conduttività termica Conductivité thermique

Compressive strength at 25 °C. Druckfestigkeit bei 25° C 520 Mpa
 Resistenza allo schiacciamento a 25 °C Résistance à la compression à 25° C

Compressive strength at 200 °C. Druckfestigkeit bei 200° C 350 Mpa
 Resistenza allo schiacciamento a 200 °C Résistance à la compression à 200° C

Plane parallelism Flächen Parallelität 0,1 mm
 Parallelismo del piano Parallélisme du plan

NOTES: Average temperature reduction is of 30 °C

NOTE: In media la riduzione di temperatura è di 30°C

ACHTUNG: Die mittlerer Temperatursenkung ist 30°C

NOTE: La réduction moyenne de température est de 30°C

	Assembly	Montage	Montaggio	Montage
1	Mold	Werkzeug	Stampo	Moule
2	Key	Passfeder	Chiavetta	Clavette
3	Key fixing screws (two for cylinder) – included Befestigungsschrauben (zwei für Zylinder) – enthalten Viti per fissaggio chiavetta (due per cilindro) – in dotazione Vis de fixation (deux par vérin) – inclus			
4	Insulating plate	Isolierplatte	Piastra	Plaque
5	Cylinder	Zylinder	Cilindro	Vérin

Depth of the seat where key-way is located (see table on page E17 - E18)

Tiefe der Nut (siehe Tabelle auf Seite E17 - E18)

Profondità cava per alloggiamento chiavetta (vedi tabella pag. E17 e E18).

Profondeur du logement de la clavette (voir tableau de page E17 et E18)

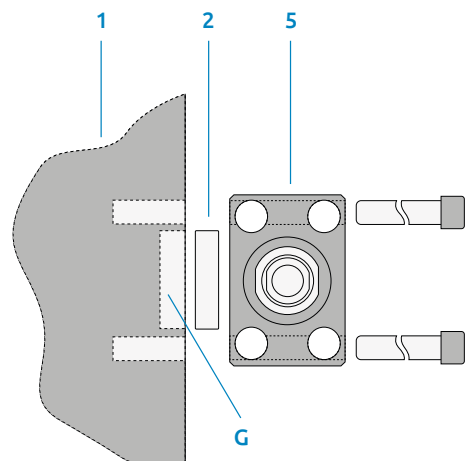
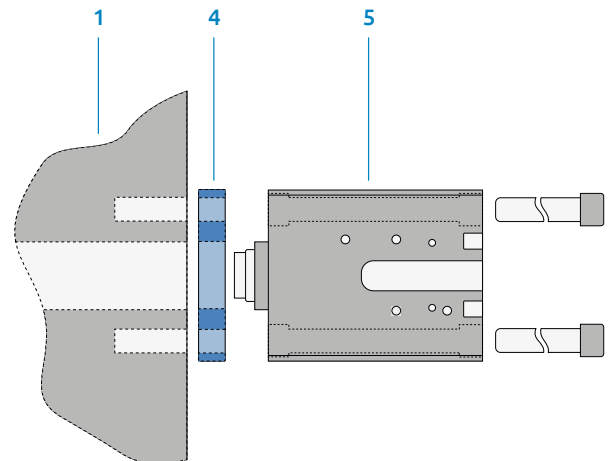
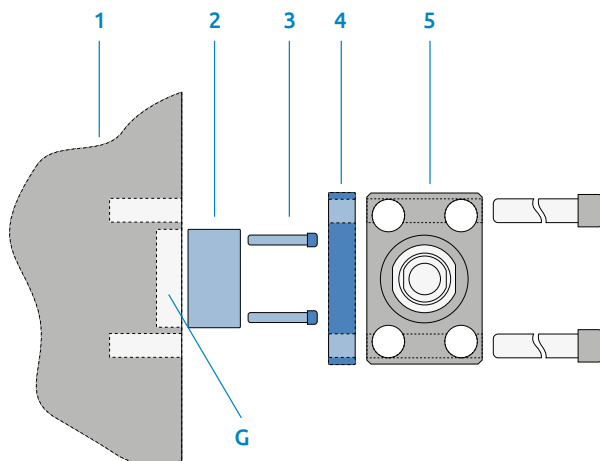

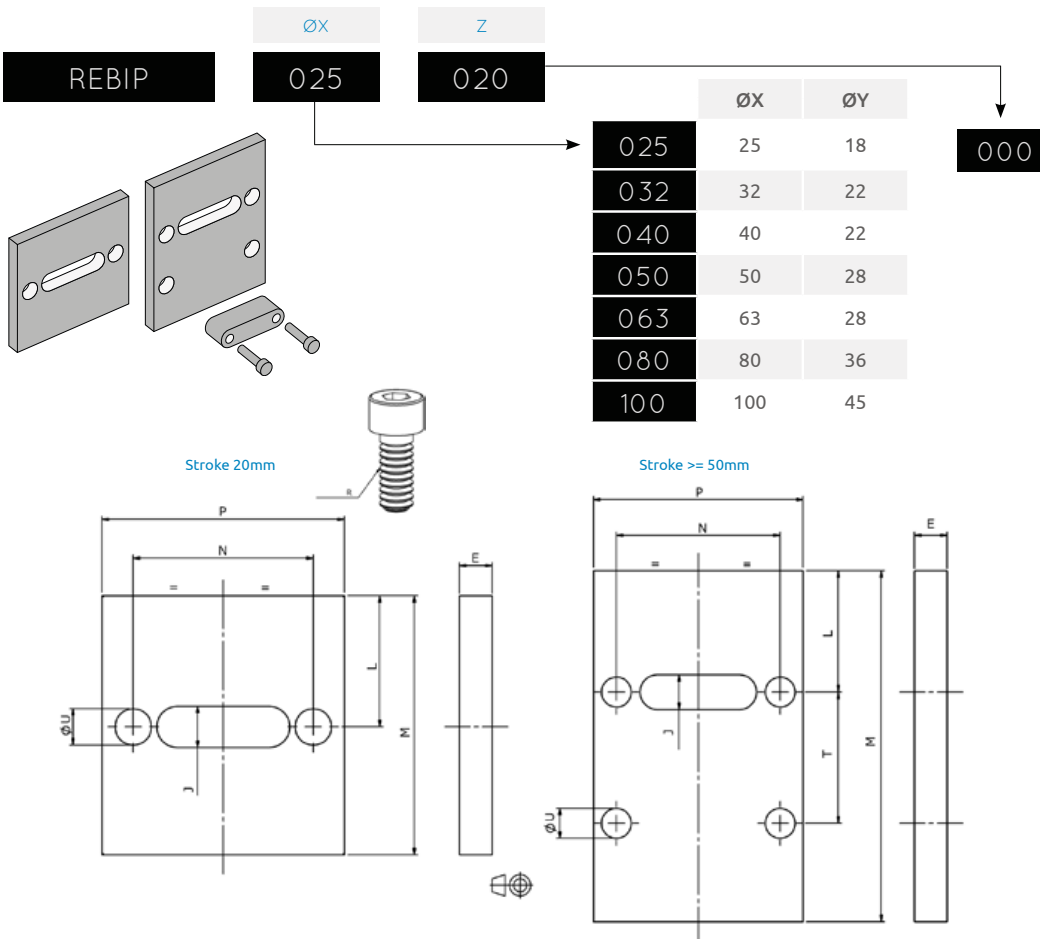

Dimension of the seat depth for the key-way on the mold. Support key and screws are included.

Maß für die Tiefe der Nut im Formwerkzeug. Einschließlich Nut und Schrauben

G: Quota corrispondente alla profondità della cava di alloggiamento chiavetta sullo stampo. La chiavetta di supporto e le viti sono incluse.

Mesure correspondant à la profondeur du logement de la clavette sur le moule. Clavette de support et vis sont incluses.

ØX	ØY	Z	B ^{-0,10 -0,20}	C	E	G	H	I ^{+0 -0,03}	J	L	M+	N	P	R	S	T	ØU	ØV	ØW
25	18	20	35	15	10	3	25	10	10	37	56	50	64	M4	5	-	8,5	4,5	7,5
		40														70			
		80														70			
32	22	20	40	18	10	5	28	12	12	40	59	55	74	M5	6	-	10,5	5,5	9
		50														70			
		80														70			
40	22	20	45	18	10	5	33	12	12	43	72	63	84	M5	6	-	10,5	5,5	9
		50														75			
		80														75			
50	28	20	55	22	10	7	40	15	15	45	74	76	99	M6	7	-	13	6,5	10,5
		50														45			
		80														75			
63	28	20	70	22	10	7	55	15	15	55	84	90	114	M6	7	-	13	6,5	10,5
		50														40			
		80														70			
80	36	20	80	22	10	7	60	20	20	60	99	110	139	M10	11	-	17	10,5	16,5
		50														40			
		-														-			
100	45	20	110	22	10	7	90	20	20	70	109	135	169	M10	11	-	17	10,5	16,5
		50														30			
		-														-			

NOTES: For dimensions where no tolerance is indicated, refer to DIN norm 7168-m.

ACHTUNG: Für Maße ohne Tolleranzangaben gilt DIN 7168-m.

NOTE: Per le dimensioni senza indicazione di tolleranza, riferirsi alla norma DIN 7168-m.

NOTE: Pour les dimensions où la tolerance n'est pas indiquée, adressez-vous aux normes DIN 7168-m.

ØX Bore Bohrung Alesaggio Alésage ØY Rod Kolbenstange Stelo Tige Z Stroke Hub Corsa Course

V250CE

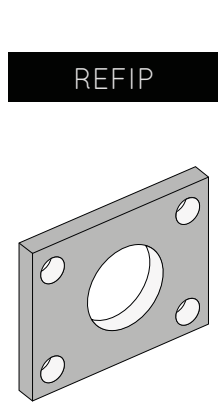

ØX	ØY
025	18
032	22
040	22
050	28
063	28
080	36
100	45

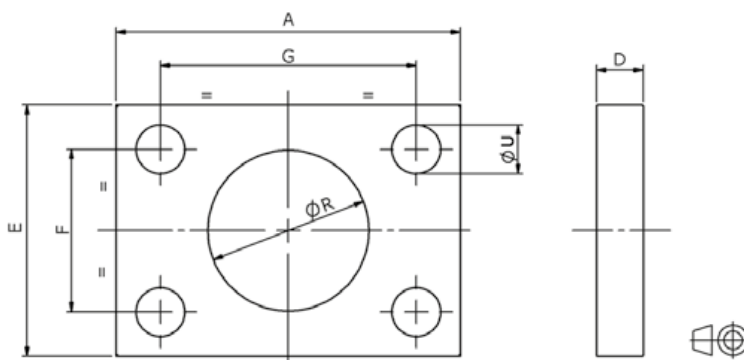

NOTES: Not available with frontal oil delivery "F". **ACHTUNG:** Nicht erhältlich mit frontalem Ölschluß "F".

NOTE: Non disponibile con alimentazione olio frontale "F". **NOTE:** Non disponible avec alimentation intégrée arrière "F".

ØX	ØY	A	D	E	F	G	ØR	ØU
25	18	64	10	44	30	50	32	8,5
32	22	74	10	54	35	55	34	10,5
40	22	84	10	62	40	63	34	10,5
50	28	99	10	74	45	76	42	13
63	28	114	10	89	55	90	50	13
80	36	139	10	109	75	110	60	17
100	45	169	10	139	95	135	72	17

NOTES: For dimensions where no tolerance is indicated, refer to DIN norm 7168-m. **ACHTUNG:** Für Maße ohne Toleranzangaben gilt DIN 7168-m.

NOTE: Per le dimensioni senza indicazione di tolleranza, riferirsi alla norma DIN 7168-m. **NOTE:** Pour les dimensions où la tolerance n'est pas indiquée, adressez-vous aux normes DIN 7168-m.

Key for Lateral Mounting Nut für seitliche Befestigung Chiavetta per fissaggio laterale Clavette pour fixation inférieure

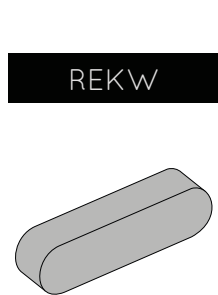

ØX	ØY
025	18
032	22
040	22
050	28
063	28
080	36
100	45

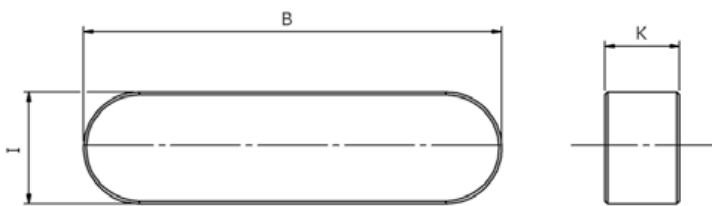

Dimension of the seat depth for the key-way on the mold.

Maß für die Tiefe der Nut im Formwerkzeug

G: Quota corrispondente alla profondità della cava di alloggiamento chiavetta sullo stampo.

Mesure correspondant à la profondeur du logement de la clavette sur le moule.

ØX	ØY	B ^{-0,10 -0,20}	G	I ^{+0 -0,03}	K
25	18	35	3	10	5
32	22	40	5	12	8
40	22	45	5	12	8
50	28	55	7	15	12
63	28	70	7	15	12
80	36	80	7	20	12
100	45	110	7	20	12

NOTES: For dimensions where no tolerance is indicated, refer to DIN norm 7168-m. **ACHTUNG:** Für Maße ohne Toleranzangaben gilt DIN 7168-m.

NOTE: Per le dimensioni senza indicazione di tolleranza, riferirsi alla norma DIN 7168-m. **NOTE:** Pour les dimensions où la tolerance n'est pas indiquée, adressez-vous aux normes DIN 7168-m.

ØX Bore Bohrung Alesaggio Alésage ØY Rod Kolbenstange Stelo Tige Z Stroke Hub Corsa Course

1	Double magnetic switch Magnetischer Doppelschalter Doppio sensore magnetico Double détecteur magnétique
2	Switch fixing screw, two for cylinder Klemmschrauben für Sensor, zwei pro Zylinder Vite di fissaggio sensore, due per cilindro Vis de fixation pour détecteurs, deux par vérin
3	Piston seals Dichtungssatz Kolben Guarnizioni pistone Joints du piston
4	Piston Kolben Pistone Piston
5	Rod cartridge Führungsbuchse Cartuccia porta guarnizioni stelo Cartouche de la tige
6	Rod seals Dichtungsset Kolbenstange Guarnizioni stelo Joints de la tige
7	Rod Kolbenstange Stelo Tige
8	Magnet (magnetic version only) Magnet (magnetische Version) Magnete (solo versione magnetica) Aimant (version magnétique uniquement)
9	Body Körper Corpo Corps

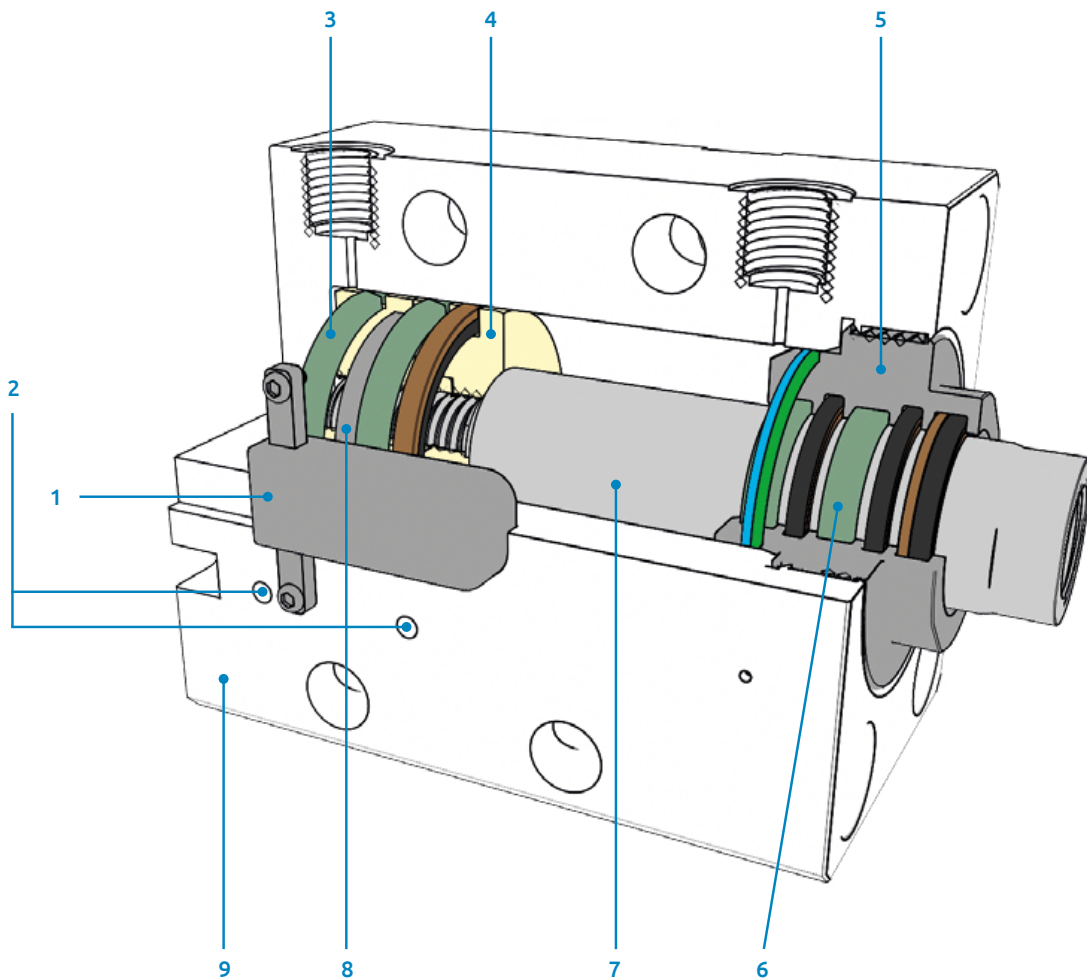

V250 CE

Type Modell Modello Modèle	Cylinder bore Zylinder Bohrung Alésaggio cilindro Alésage vérin	Article Code Artikelcode Codice Articolo Code Article	Additional set code Zusätzlicher Kode Indicazione d'assieme Indication d'ensemble	Cylinder stroke Hub Corsa cilindro Course du vérin					
RE	...	6010	A		Rod seals kit	Dichtungssatz Kolbenstange	Serie guarnizioni stelo	Série joints de la tige	6
RE	...	6020	A		Piston seals kit	Dichtungssatz Kolben	Serie guarnizioni pistone	Série joints du piston	3
RE	...	6030			FKM O-ring for integrated oil delivery	O-ring für integrierte Ölschlüsse in FKM	O-ring alimentazione integrata in FKM	Joints torique en FKM pour l'alimentation de l'huile intégrée	
RE	...	0310			Rod cartridge without seals	Führungsbuchse ohne Dichtungen	Cartuccia stelo senza guarnizioni	Cartouche de la tige sans joints	5
RE	...	0310	A		Rod cartridge with seals	Führungsbuchse mit Dichtungen	Cartuccia stelo con guarnizioni	Cartouche de la tige avec joints	5+6
RE	...	6050			Magnet	Magnet	Magnete	Aimant	8
RE	...	1520	A		Non-magnetic piston with seals	Kolben mit Dichtungen für nicht magnetische Ausführung	Pistone non magnetico con guarnizioni	Piston non magnétique avec joints	3+4
RE	...	1510	A		Magnetic piston with seals	Magnetischer Kolben mit Dichtungen	Pistone magnetico con guarnizioni	Piston pour vérin magnétique avec joints	3+4+8
RE	...	1120		...	Rod with Female Metric Thread Rod End "G"	Kolbenstange "G", mit metrischem Innengewinde am Ende	Stelo con estremità filetto femmina metrico "G"	Tige avec extrémité taraudage métrique "G"	7
RE	...	1121		...	Rod with Female UNF Thread Rod End "I"	Kolbenstange "I" mit Innengewinde UNF (USA Standard) am Ende	Stelo con estremità filetto femmina UNF (USA Standard) "I"	Tige avec extrémité taraudage UNF-UNEF "I"	7
RE	...	1530	A	...	Magnetic rod-piston group with Female Metric Thread Rod End "G"	Gruppe Kolben-Stange mit Kolbenstangenende "G", magnetisch	Gruppo stelo-pistone magnetico con estremità filetto femmina metrico "G"	Groupe tige-piston magnétique avec extrémité taraudage métrique "G"	3+4+7+8
RE	...	1531	A	...	Magnetic rod-piston group with Female UNF Thread Rod End (USA Standard) "I"	Gruppe Kolben-Stange mit Kolbenstangenende « I », magnetisch "I"	Gruppo stelo-pistone magnetico con estremità filetto femmina UNF (USA Standard) "I"	Groupe tige-piston magnétique avec extrémité taraudage UNF-UNEF (USA Standard) "I"	3+4+7+8
RE	...	1540	A	...	Non-magnetic rod-piston group with Female Metric Thread Rod End "G"	Gruppe Kolben-Stange mit Kolbenstangenende "G", normal	Gruppo stelo-pistone normale con estremità filetto femmina metrico "G"	Groupe tige-piston non magnétique avec extrémité taraudage métrique "G"	3+4+7
RE	...	1541	A	...	Non-magnetic rod-piston group with Female UNF Thread Rod End (USA Standard) "I"	Gruppe Kolben-Stange mit Kolbenstangenende "I", normal	Gruppo stelo-pistone normale con estremità filetto femmina UNF (USA Standard) "I"	Groupe tige-piston non magnétique avec extrémité taraudage UNF-UNEF (USA Standard) "I"	3+4+7

Type	Modell	Modello	Modèle	Cylinder bore	Article Code	Additional set code	Cylinder stroke	
Modell	Modello	Modèle	Zylinder Bohrung	Artikelcode	Zusätzlicher Kode	Hub		
Modello	Modèle	Alésage vérin	Codice Articolo	Indicazione d'insieme	Indication d'ensemble	Corsa cilindro		
Modèle	Zylinder Bohrung	Alésage vérin	Code Article	Indicazione d'insieme	Indication d'ensemble	Course du vérin		
RE	...	1930 F	...	025	6010	A		<p>Body for clamping style "C", frontal oil ports with O-Rings Körper für Befestigungsart "C", Anschluß mit O-Ringen vorne Corpo fissaggio "C", orifici tipo O-ring frontali Corps fixation "C", orifices intégrés avant</p>
RE	...	1930 R	...	025	6010	A		<p>Body for clamping style "C", back oil ports with O-Rings Körper für Befestigungsart "C", Anschluß mit O-Ringen hinten Corpo fissaggio "C", orifici tipo O-ring posteriori Corps fixation "C", orifices intégrés arrière</p>
RE	...	1920 M	...	025	6010	A		<p>Body for clamping style "E", BSP right-positioned threaded holes Körper für Befestigungsart "E", Gewindebohrung BSP rechts Corpo fissaggio "E", orifici filettati BSP lato destro Corps fixation "E", orifices filetés BSP côté droit</p>
RE	...	1920 H	...	025	6010	A		<p>Body for clamping style "E", BSP left-positioned threaded holes Körper für Befestigungsart "E", Gewindebohrung BSP links Corpo fissaggio "E", orifici filettati BSP lato sinistro Corps fixation "E", orifices filetés BSP côté gauche</p>
RE	...	1924 M	...	025	6010	A		<p>Body for clamping style "E", NPT right-positioned threaded holes Körper für Befestigungsart "E", Gewindebohrung NPT rechts Corpo fissaggio "E", orifici filettati NPT lato destro Corps fixation "E", orifices filetés NPT côté droit</p>
RE	...	1924 H	...	025	6010	A		<p>Body for clamping style "E", NPT left-positioned threaded holes Körper für Befestigungsart "E", Gewindebohrung NPT links Corpo fissaggio "E", orifici filettati NPT lato sinistro Corps fixation "E", orifices filetés NPT côté gauche</p>
RE	...	1934 E	...	025	6010	A		<p>Body for clamping style "E", lateral oil ports with O-Ring Körper für Befestigungsart "E", Anschluß mit O-Ringen seitlich Corpo fissaggio "E", orifici tipo O-ring laterali Corps fixation "E", orifices intégrés dessous</p>
RE	...	1920 D	...	025	6010	A		<p>Body for clamping style "E", BSP right and left-positioned threaded holes Körper für Befestigungsart "E", Gewindebohrung BSP rechts und links Corpo fissaggio "E", orifici filettati BSP lato destro e sinistro Corps fixation "E", orifices filetés BSP côté gauche et côté droit</p>
RE	...	1924 D	...	025	6010	A		<p>Body for clamping style "E", NPT right and left-positioned threaded holes Körper für Befestigungsart "E", Gewindebohrung NPT rechts und links Corpo fissaggio "E", orifici filettati NPT lato destro e sinistro Corps fixation "E", orifices filetés NPT côté gauche et côté droit</p>
RE	...	6301	...	025	6010	A		<p>Switch fixing screw, two for cylinder Klemmschrauben für Sensor, zwei pro Zylinder Vite di fissaggio sensore, due per cilindro Vis de fixation pour détecteurs, deux par vérin</p>
		MSU2						<p>Multi-function switch Kompletter Endschalter Interruttore completo Détecteur complet</p>
		MSU3						<p>Multi-function switch Kompletter Endschalter Interruttore completo Détecteur complet</p>

V250 CE



CONTACT FOR NORTH AMERICAN
SALES AND TECHNICAL SUPPORT



ALBA ENTERPRISES, LLC

2730 Monterey Street Suite 103, Torrance, CA 90503
PH: 909.941.0600 • 800.432.6653 • FX: 909.941.0190
Email: info@albaent.com • www.ALBAENT.com